

---

# Scantech Castor C-5010

## Bar code laser scanner





# **User's manual**

---

**Scantech Castor C-5010**

## **Copyright © 2003, Scantech-ID BV.**

This manual is copyrighted, with all rights reserved. Under the copyright laws, this manual may not, in whole or in part, be copied, photocopied, reproduced, translated or converted to any electronic medium or machine readable form without prior written consent of Scantech-ID BV.

## **Limited Warranty**

Under all circumstances this manual should be read attentively, before installing and/or using the product. In no event shall Scantech-ID BV be liable for any direct, indirect, special, consequential or incidental damages arising out of the use or inability to use this documentation or product, even if advised of the possibility of such damages. In particular, Scantech-ID BV shall not be liable for any hardware, software, or data that is stored or used with the product, including the cost of repairing, replacing or recovering the above. Scantech-ID BV reserves the right to change parts of the device at any time without preceding or direct announcement to the client.

Scantech-ID BV reserves the right to revise this manual, and to make changes in the contents without obligation to notify any person or entity of the revision or change. A serial number appears on the product. Make sure that this official registration number has not been removed. It should be used whenever servicing by Scantech-ID BV or an authorized Scantech dealer is necessary.

## **Important**

This equipment has been tested and found to comply with the limits for a Class B digital device, pursuant to EN55022, and with the limits for a class A digital device, pursuant to part 15 of the FCC rules. These limits are designed to provide reasonable protection against harmful interference when the equipment is operated in a commercial environment. This equipment generates, uses, and can radiate radio frequency energy and, if not installed and used in accordance with the user's manual, may cause harmful interference to radio communications. Operation of the equipment in a residential area is likely to cause harmful interference in which case the user will be required to correct the interference at his own expense. Any unauthorized changes or modifications to this equipment could void the user's authority to operate this equipment.

*For CE-countries:*

- The Castor is in conformity with the CE standards. Please note that a Scantech CE-marked power supply unit should be used to conform to these standards.

*For USA & Canada:*

- To be used with UL listed and CSA certified computers/POS systems. This scanner should only be powered by a UL Listed/CSA Certified power supply having Limited Power Source or Class2 outputs, rated + 5 V dc/0.75A, + 12 V dc/1A, -12 V dc/0.05A and minimum 40 degrees Celcius operating environment.

- À utiliser avec des ordinateurs/systèmes POS enregistrés UL/certifiés CSA.

## **Radio and television interference**

Operation of this equipment in a residential area can cause interference with radio or television reception. This can be determined by turning the equipment off and on. The user is encouraged to try to correct the interference by one or more of the following measures:

- Re-orientate the receiving antenna
- Relocate the device with respect to the receiver
- Move the device away from the receiver
- Plug the device into a different outlet in order to have the device and receiver on different branch circuits

If necessary, the user should consult the manufacturer, an authorized Scantech dealer or experienced radio/television technician for additional suggestions. The booklet "*How to Identify and Resolve Radio-TV Interference Problems*", prepared by the Federal Communications Commission, can be of help. It can be obtained from the U.S. Government Printing Office, Washington, DC 20402, Stock No. 004000003454.

# Table of contents

---

<b>Preface</b>		<b>i</b>
<b>Chapter 1</b>	<b>The Castor C-5010</b>	<b>1</b>
	1.1 Unpacking the Castor C-5010	2
	1.2 Scanning bar codes with the Castor C-5010	4
	1.3 Scanner labelling	5
	1.4 Maintaining the scanner	8
	1.5 Releasing the scanner top deck	8
	1.6 Controlling the scanner from the POS system	9
<b>Chapter 2</b>	<b>Installing the Castor C-5010</b>	<b>11</b>
	2.1 Installing the scanner in counter	12
<b>Appendices</b>	<b>A. Connector types and pin definitions</b>	<b>16</b>
	<b>B. Technical specifications</b>	<b>18</b>
	<b>C. Troubleshooting</b>	<b>19</b>

# Preface

---

The Castor C-5010 is the high performance food retail bar code laser scanner, optimized for horizontal scanning. Thanks to its real vertical scan lines, the need to lift and tilt the product being scanned has disappeared and operator fatigue is reduced. Consequently, checkout efficiency increases.

The Castor's stainless steel top deck ensures long scanner life time. Together with its metal housing, the Castor is well protected against harmful interference from the moving belt's motor. The scanning performance is not affected by shocks, thanks to a shock proof scanner housing suspension. Since the Castor's height is only 75 mm, installation is flexible and ergonomic under all circumstances.

The Castor features Scantech's unique and patented Goldrush polygon technology. Evaporated gold gives a long maintenance free polygon. The ultra light weight ensures a long motor life and faster 'wake-up' times from the energy saving sleep mode.

Scantech's Scantium decoder ensures optimum performance on all occasions for multi-decoding tasks. The STAR software enables the Castor to read damaged and substandard bar codes. In addition, a flash EPROM gives the possibility to upgrade the firmware within the twinkling of an eye.

An auxiliary port is standard, for connecting other Scantech-ID scanners. A handheld scanner, for example, can be connected for heavy or voluminous products. A bi-optic scanning solution is realized by connecting the Castor with a vertically installed Pollux, creating the so called Gemini, transforming your checkout in a high volume throughput system.

This manual contains two chapters and three appendices. The first chapter describes the Castor and its general features. Installation instructions are described in the second chapter. Follow the installation instructions precisely. Default settings can be changed with the bar code labels in the Configuration Guide provided with the scanner.

Appendix A illustrates all scanner connectors. Technical specifications are found in Appendix B. If the scanner is not working properly, refer to Appendix C for hints.

# **Chapter 1**

**The Castor C-5010**

## 1.1 UNPACKING THE CASTOR C-5010

Remove the scanner and its accessories from the box and packing material. Refer to the packing list to make sure you have received all the items ordered. Visually inspect the scanner and accessories for any evidence of physical damage. Refer to the figure on page 5 to locate the interface label and make sure that the scanner interface corresponds with the host system interface. Immediately contact your supplier if anything appears to be damaged, or if the supported interface does not correspond with the host system interface.

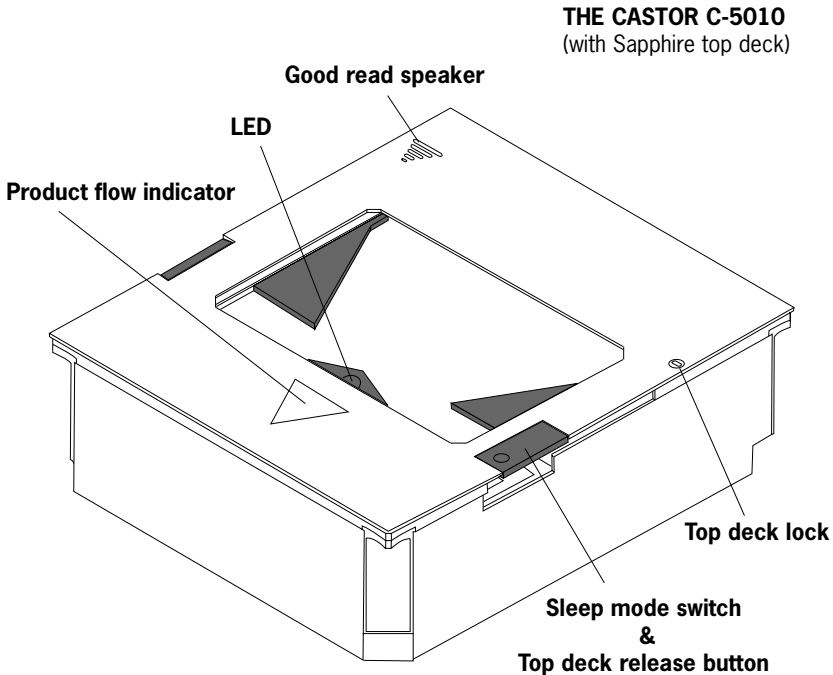

The various parts of the Castor C-5010 are:

**Sleep mode switch** - When a sleep mode time-out is programmed, the scanner can be re-activated by gently pressing this switch. The sleep mode feature is programmable with the menu labels from the Configuration Guide.

**NOTE:** The default value for the sleep mode time-out is set to 30 minutes. When the scanner is in sleep mode, the LED is intermittently flashing red.

**Top deck release button** - Pushing this button will release the top deck for maintenance or replacement.

**Top deck lock** - Before pushing the top deck release button, the top deck lock must be unlocked.

**LED** - A red LED indicates that the scanner is ready to read a bar code. A green LED indicates a good read.

**Good read speaker** - The speaker is heard whenever data has been read correctly. The frequency and volume can be adjusted with the menu labels from the Configuration Guide.

**Product flow indicator** - The product flow indicator indicates the direction in which products must be passed along the scanner.

### 1.2 SCANNING BAR CODES WITH THE CASTOR C-5010

The Castor C-5010 is an omni-directional scanner featuring a 5 directional scan field with a 15 lines scan pattern. The scanner's scan volume is illustrated in the figure below. The optimal reading zone lies between 0 and 7 cm from the scanner window, but bar codes can be read up to 30 cm (11.8 in.) from the scanner window.

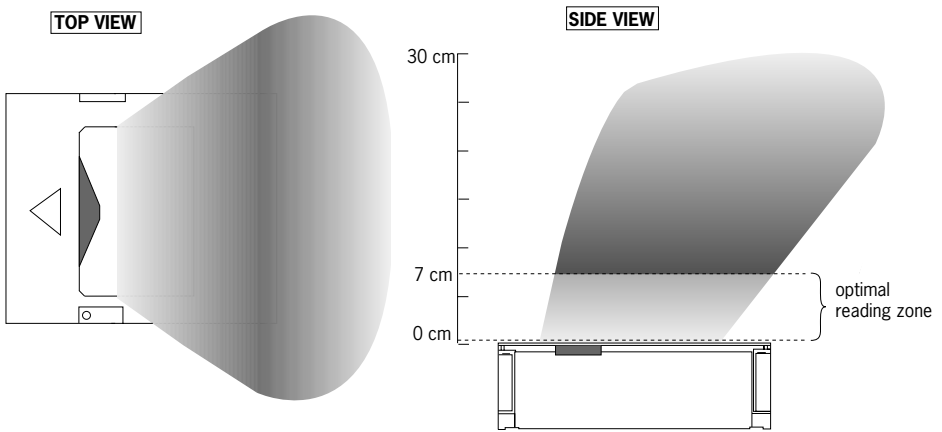

Scanning a bar code label is very simple: pass the product's bar code label along the scanner as illustrated in the figure below.

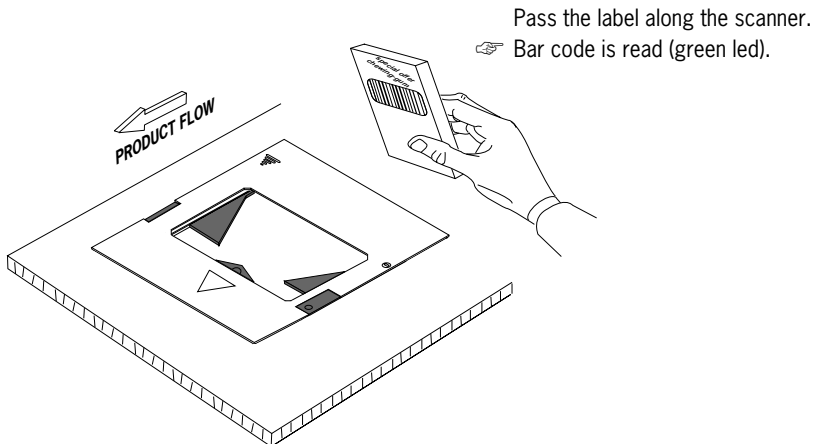

### 1.3 SCANNER LABELLING

Three labels are present on the housing of the Castor C-5010 as indicated in the figure below. Two labels are also visible through the scanner window. All labels are attached by the manufacturer and should not be removed.

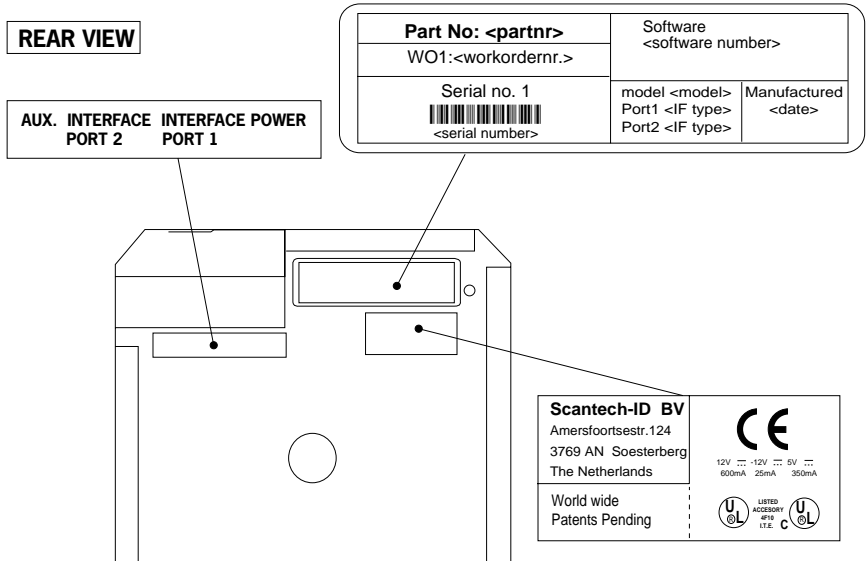

The scanner's serial number is found underneath the bar code label as depicted in the figure above. This official registration number is strictly related to the device. The supplier may ask for this number when the scanner needs servicing.

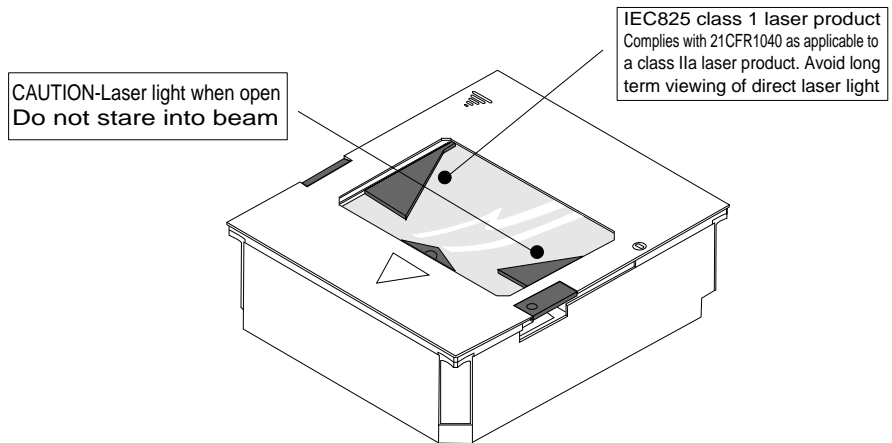

## **Laser safety**

### **English:**

The C-5010 scanner complies with safety standard IEC 825-1 (1993) for a Class I laser product. It also complies with U.S. 21CFR1040 as applicable to a Class Ila laser product. Avoid long term viewing of direct laser light.

### **German:**

Der Strichcode-Scanner C-5010 entspricht den Sicherheitsvorschriften nach IEC 825-1 (1993) für ein Laserprodukt der Klasse I. Er entspricht auch U.S. 21CFR1040, anwendbar auf ein Laserprodukt der Klasse Ila. Vermeiden Sie langzeitiges Hineinblicken in direktes Laserlicht.

### **Dutch:**

De C-5010 scanner voldoet aan de veiligheidsnormen IEC 825-1 (1993) voor een Klasse I laserprodukt. Tevens voldoet de scanner aan U.S. 21CFR1040, van toepassing op een Klasse Ila laserprodukt. Vermijd langdurig kijken in direct laserlicht.

### **French:**

Le scanner C-5010 est conforme aux normes de sécurité IEC 825-1 (1993) s'appliquant à un produit laser de la classe I. Il est également conforme à la U.S. 21CFR1040 telle qu'elle s'applique à un produit laser de la classe Ila. Eviter de rester exposé longtemps à la lumière directe du laser.

### **Danish:**

C-5010 skanneren er i overensstemmelse med sikkerhedsstandarden IEC 825-1 (1993) for laserprodukter i klasse I. Den er også i overensstemmelse med U.S. 21CFR1040, der gælder for laserprodukter i klasse Ila. Undgå at se direkte på laserlys i længere perioder.

### **Finnish:**

C-5010 -skanneri täyttää luokan I lasertuotteelle IEC 825-1:ssä (1993) asetetut turvavaatimukset. Se täyttää myös U.S. 21CFR1040:ssa asetetut vaatimukset siltä osin kuin ne koskevat luokan Ila lasertuotetta. Vältä pitkäaikaista suoraan laservaloon katsomista.

### **Swedish:**

Avsökaren C-5010 uppfyller säkerhetsnormen IEC 825-1 (1993) för laserprodukter av klass I. Den uppfyller dessutom U.S. 21CFR1040 som gäller för laserprodukter av klass Ila. Undvik att titta i direkt laserljus under längre perioder.

**Norwegian:**

C-5010 skanneren er i samsvar med sikkerhetsstandarden IEC 825-1 (1993) for laserprodukter i klasse I. Den er også i samvar med U.S. 21CFR1040 for laserprodukter i klasse IIa. Unngå å se langvarig på direkte laserlys.

**Italian:**

Lo scanner C-5010 è conforme alle norme di sicurezza IEC 825-1 (1993) relative ad un prodotto laser di Classe 1. È inoltre conforme alla norma U.S. 21CFR1040 relativa ad un prodotto laser di Classe IIa. Evitare l'esposizione prolungata all'emissione diretta di luce laser.

**Portuguese:**

O scanner C-5010 está conforme as normas de segurança IEC 825-1 (1993) para a Classe 1 dos produtos laser. Também está conforme a norma U.S. 21CFR1040 aplicada nos produtos laser da Classe IIa. Evite expor os olhos directa e prolongadamente aos raios laser.

**Spanish:**

El scanner C-5010 reúne las normas de seguridad IEC 825-1 (1993) para un producto laser de Clase 1. También reúne las normas U.S. 21CFR1040 que se aplican a un producto laser de Clase IIa. Se debe evitar mirar muy fijo en luz láserica directa.

**Optical:** The use of optical instruments with this product will increase eye hazard. Optical instruments include binoculars, microscopes and magnifying glasses but do not include eye glasses worn by the user.

**Radiant Energy:** The C-5010 uses a low-power laser diode operating at 670 nm in an opto-mechanical scanner resulting in less than 0.6 mW peak output power. Laser light observed at 2,8 cm (1.1 in.) above the window through a 7 mm (0.28 in.) aperture and averaged over 1000 seconds is less than 3.9  $\mu$ W per CDRH Class IIa specification. Do not attempt to remove the protective housing of the scanner, as unscanned laser light with a peak output up to 0.9 mW could be accessible inside.

**Laser Light Viewer:** The scanner window is the only aperture through which laser light may be observed on this product.

A failure of the scanner motor, while the laser diode continues to emit a laser beam, may cause emission levels to exceed those for safe operation. The scanner has safeguards to prevent this occurrence. If, however, a stationary laser beam is emitted, the failing scanner should be disconnected from its power source immediately.

**Adjustments:** Do not attempt any adjustments to or alteration of this product. Do not remove the scanner's protective housing. There are no user-serviceable parts inside.

**CAUTION: Use of controls or adjustments or performance of procedures other than those specified herein may result in hazardous laser light exposure.**

## 1.4 MAINTAINING THE SCANNER

The Castor C-5010 scanner requires little maintenance. Only occasional cleaning of the scanner window is necessary to remove dirt and fingerprints. Cleaning can be performed during operation with a non-abrasive glass spray cleaner and a soft lint-free cloth.

## 1.5 RELEASING THE SCANNER TOP DECK

The top deck of the Castor can be released for replacement. To release the top deck follow the illustrations below.

### NOTE

- The scanner and the host system must be switched off before starting the replacement of the top deck.

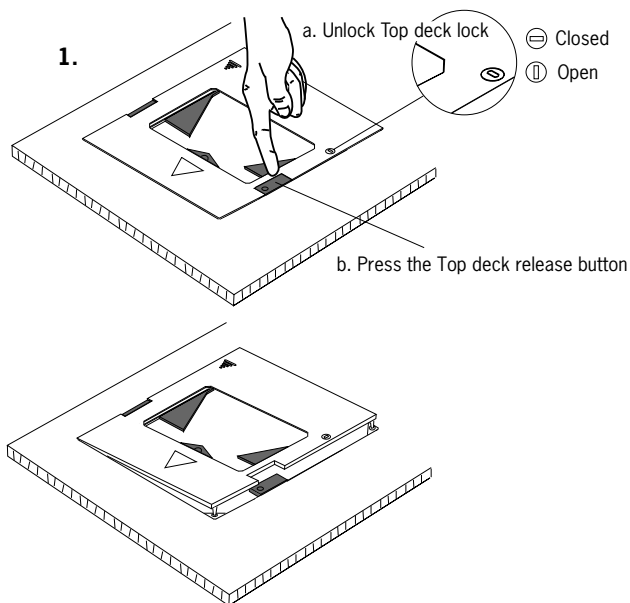

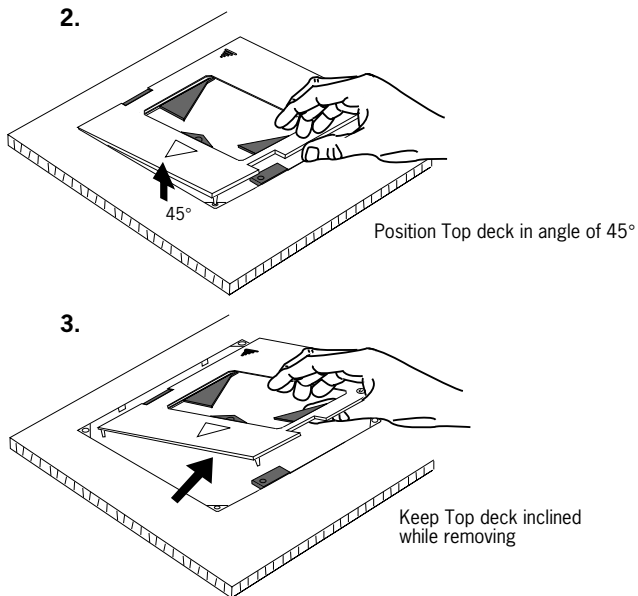

### 1.6 CONTROLLING THE SCANNER FROM THE POS SYSTEM

The Castor C-5010 can be controlled from the POS system via the RS232C interface. Control is achieved by transmitting the following single byte commands to the scanner. In the Scantech default setting the following commands are available (more details upon request):

ASCII code	function	byte is also called:
05 Hex	power-up re-initialization	ENQ or <Ctrl-E>
0E Hex	enable (cancels disable)	Shift Out or <Ctrl-N>
0F Hex	disable	Shift In or <Ctrl-O>
12 Hex	sleep	DC2 or <Ctrl-R>
14 Hex	wake (cancels sleep)	DC4 or <Ctrl-T>

When the scanner is disabled, the motor of the scanner will stay on until the scanner goes into sleep mode.

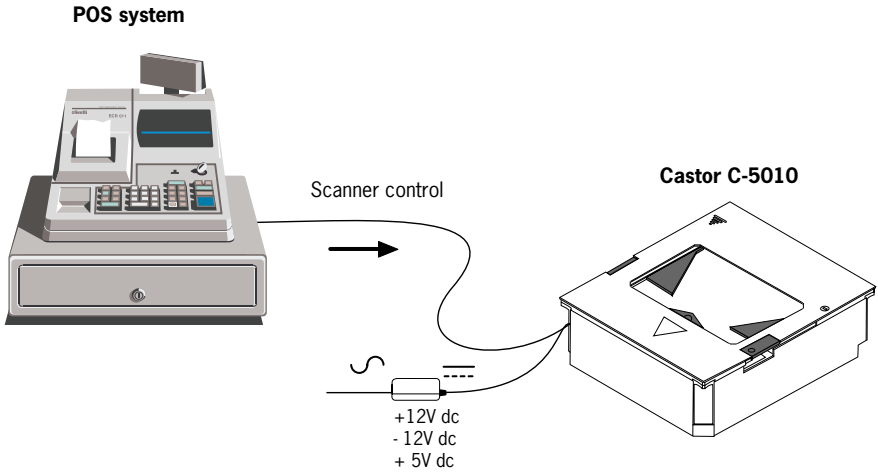

# **Chapter 2**

## **Installing the Castor C-5010**

The Castor C-5010 is designed to be installed horizontally (in the counter). Instructions for installation are given in Section 2.1.

Due to many POS systems on the market, a large number of communication cables is available. Make sure that you have the right cable to connect the scanner to your POS or computer.

### NOTES

- The scanner and the host system must be switched off before starting the installation of the scanner. By following this precaution you prevent any electrical damage.
- You are advised to install the scanner in an air circulated place out of direct sunlight

## 2.1 INSTALLING THE SCANNER IN COUNTER

Follow these steps to install the scanner in the counter:

1. Locate the optimum scanner position in the counter surface. Pay attention to the product flow, distance to the counter edge and convenience for the operator.
2. Choose one of the following mounting options to install the Castor:
  - A. Using the bottom of the Castor as support,
  - B. Using the horizontal mount (separately ordered).

### A. Using the bottom of the Castor as support

- Cut a hole in the counter surface following the illustration below.
- Design a supporting shelf following the illustration precisely.

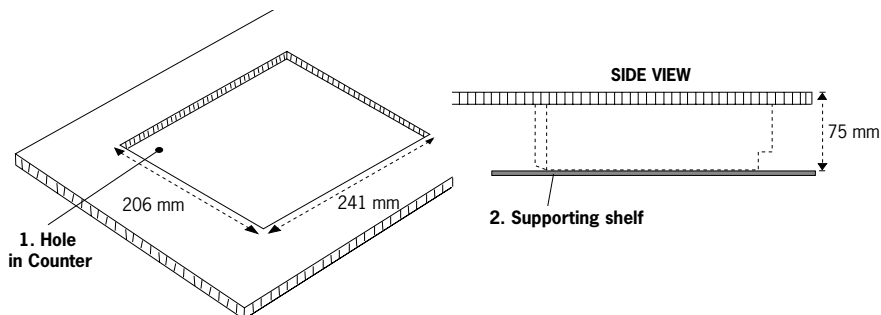

## B. Using the horizontal mount

- Cut a hole in the counter surface following the illustration below.
- Fit the horizontal mount in the hole.

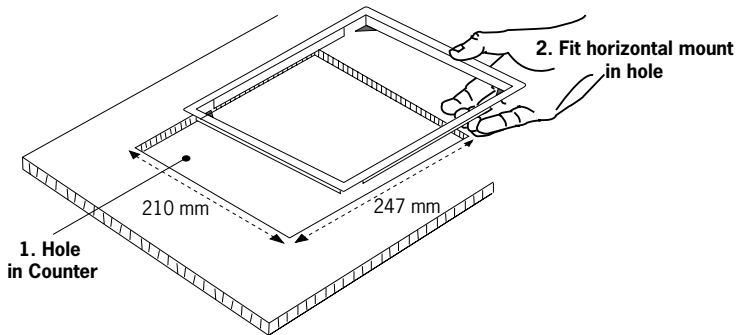

3. Lead the power supply cable and communication cable through the hole in the counter.
4. Plug the communication cable with the 8 pin modular jack into Data port 1 if the host system features the RS232C or IBM RS485 interface, or into Data port 2 if the host system features the OCIA or KBW interface. Plug the other connector of the cable into the appropriate serial port of your POS or computer. Connect the Scantech universal power supply unit to the power supply port.

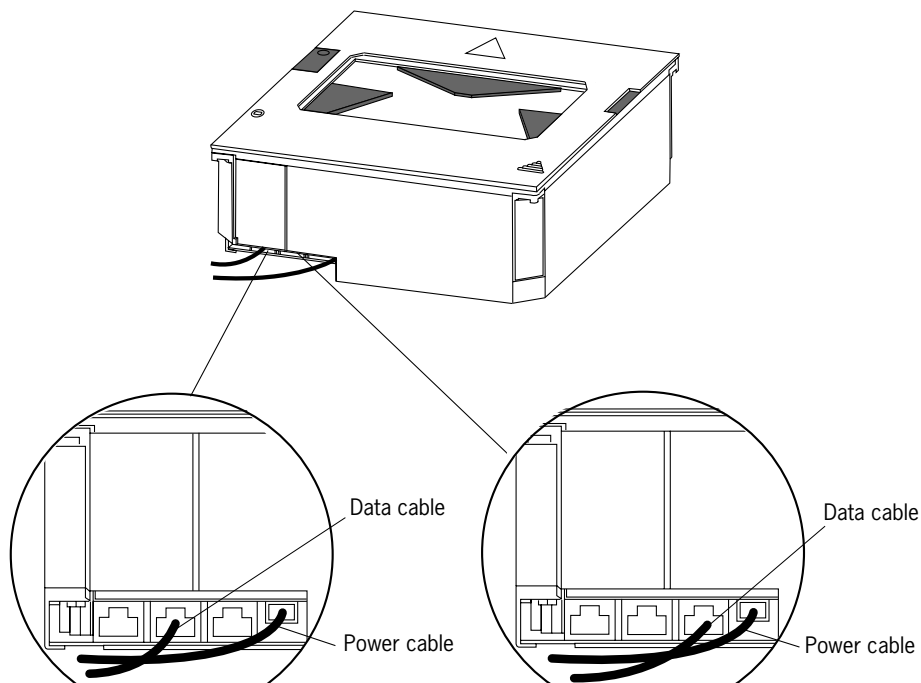

**Data port 2.** Connect the communication cable to this port if the host system features the **OCIA** or **KBW** interface

**Data port 1.** Connect the communication cable to this port if the host system features the **RS232C** or **IBM RS 485** interface

5. Place the scanner in the counter hole. Pay attention to the product flow!
6. Remove the top deck protection foil.
7. Power on the scanner by connecting the IEC power cord to the AC/DC power supply and plugging the AC power cord into an AC power outlet. Switch on the host system.

### IMPORTANT

- To activate Data port 2 (**OCIA** or **KBW** interface) scan the following codes from the Configuration Guide:
  1. **open** the scanner Programming Mode by scanning code 1.1
  2. **return to factory default settings** by scanning code 1.3

Once the scanner is installed, you can start scanning bar code labels. If you want to change the default settings of the scanner, proceed to the Configuration Guide which came with the scanner.

# **Appendices**

**A. Connector types and pin definitions**

**B. Technical Specifications**

**C. Troubleshooting**

### A. CONNECTOR TYPES AND PIN DEFINITIONS

There are two dual interface versions of the Castor available: RS232C/OCIA and IBM RS485/Keyboard Wedge. The various pin definitions for the applicable Data port are given on page 17. The connector to be used for the port is indicated below.

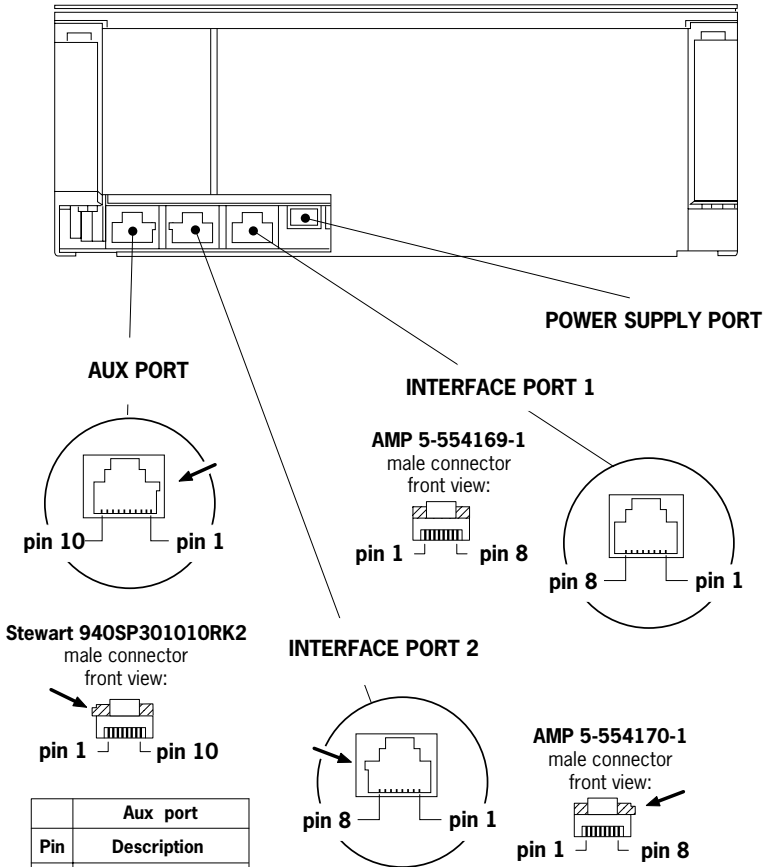

Aux port	
Pin	Description
1	+5VDC (250 mA max.)
2	CTS
3	RXD
4	Reserved
5	RTS
6	GND
7-10	Reserved

**Pin definition for dual interface version RS232C-OCIA**

<b>RS232C interface Data port 1</b>		
<b>Pin</b>	<b>Description</b>	<b>Direction</b>
1	CTS	input
2	RXD	input
3	TXD	output
4	RTS	output
5	GND	-
6	Not Con.	-
7	Reserved	
8		

<b>OCIA interface Data port 2</b>		
<b>Pin</b>	<b>Description</b>	<b>Direction</b>
1	IFID	input
2	DATA	output
3	DATA RTN	output
4	CLOCK IN	input
5	GND	-
6	CLOCK IN RTN	input
7	RESET	input
8	RESET RTN	input

**Pin definition for dual interface version IBM RS485-Keyboard Wedge**

<b>IBM RS485 interface Data port 1</b>		
<b>Pin</b>	<b>Description</b>	<b>Direction</b>
1	Not Con.	-
2	IO-A	input/output
3	IO-B	input/output
4	Not Con.	-
5	GND	-
6	Not Con.	-
7	Reserved	
8		

<b>KBW interface Data port 2</b>		
<b>Pin</b>	<b>Description</b>	<b>Direction</b>
1	IFID1	input
2	KB_DATA	output
3	KB_CLK	output
4	PC_DATA	input
5	PC_GND	-
6	PC_CLK	input
7	PC_5V	input
8	IFID2	input

## B. TECHNICAL SPECIFICATIONS

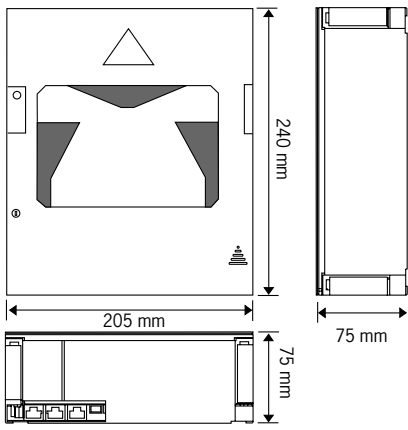
<b>Electrical</b>	
Power supply voltage	100 - 250 V ac, 50/60 Hz
DC input to scanner	+ 12 V dc, 600 mA
	- 12 V dc, 25 mA
	+ 5 V dc, 350 mA
Interfaces	Depending on scanner version
	Interface port 1: RS232 or IBM RS485
	Interface port 2: OCIA or KBW
Auxiliary port	Secondary scanner (250 mA max.)
<b>Optical</b>	
Light source	Visible laser diode (655nm)
Depth of field	300 mm
Scan pattern	5 directions scan field, 15 lines scan pattern
Scan rate	1500 scans / second
<b>Decoding</b>	
Bar code types	EAN/UPC/JAN + Add-on
	Code 128, EAN 128, Code 39, Code 32, Codabar, ITF
<b>Physical</b>	
Weight	2,5 kg
Dimensions	L x W x D: 240 x 205 x 75 mm
	: 9.45 x 8.07 x 2.95 inch
	

<b>Environmental</b>	
Operating temperature	0° C ~ 40° C
Humidity	0% ~ 95% RH (non-condensing)
<b>Safety</b>	
Laser safety	IEC 825-1 (1993) Class I, U.S. 21CFR1040 Class IIa
Electrical safety	EN 60950 second edition
Flammability rate	UL1950 (third edition), c-UL (according CSA22.2.950-95) 94V-0
<b>EM Compatibility</b>	
Radio and TV interference	EN 55022 Class B (1994), FCC part 15 Class A (1992)
Harmonic current emissions	EN 61000-3-2 (1995)
EM-immunity	EN 50082-1 (1992) based on:
ElectroStatic Discharge (ESD)	IEC 801-2 (1991)
Radio frequency immunity	IEC 801-3 (1984) / ENV 50140 (1993)
Electrical fast transient	IEC 801-4 (1988)

### C. TROUBLESHOOTING

This section contains information on solving problems you may encounter when using the scanner. If troubles occur, take a moment to read the information in this section. However, before referring to the diagnostic tips make sure that the scanner is installed as described in Chapter 2 and that all cables are properly connected.

<b>Problem</b>	<b>Diagnostic Tips</b>
The scanner is on, but a bar code cannot be read. The LED is red.	<ul style="list-style-type: none"> <li>■ The scanner window is dirty. Clean the scanner window as described in the Maintenance section.</li> <li>■ The presented bar code type is not enabled. Select the bar code type with the Configuration Guide.</li> <li>■ The scanner is disabled by the host. Refer to Section 1.6.</li> <li>■ The bar code type presented to the scanner is not supported by the Castor.</li> </ul>

Problem	Diagnostic Tips
<p>The scanner is on, but the motor is not rotating. A bar code cannot be read. The LED is intermittently flashing red.</p>	<ul style="list-style-type: none"> <li>■ The scanner is in sleep mode. Press the switch on top of the scanner to reactivate the scanner (or use the wake protocol. Refer to section 1.6).</li> </ul>
<p>The LED is alternating red/green.</p>	<ul style="list-style-type: none"> <li>■ Mirror motor is defective and must be replaced (Authorized personnel only).</li> </ul>
<p>The LED is alternating red/green and beeps are heard.</p>	<ul style="list-style-type: none"> <li>■ Possible failure of the scanning safeguard circuit. Immediately disconnect the scanner from its power source. Contact your supplier.</li> </ul>
<p>The scanner does not accept more than two or three bar codes.</p>	<ul style="list-style-type: none"> <li>■ There is no proper handshaking with the host system. Switch the host system on and check connection and communication settings.</li> </ul>
<p>The LED is red and green.</p>	<ul style="list-style-type: none"> <li>■ The laser is not functioning. The laser is defect. Contact your supplier.</li> </ul>
<p>The LED is blinking red and green.</p>	<ul style="list-style-type: none"> <li>■ The ambient temperature is too high. Make sure the scanner has enough air ventilation and is not placed in direct sunlight.</li> </ul>

<p><b>Problem</b></p>	<p><b>Diagnostic Tips</b></p>
<p>The LED remains green.</p>	<ul style="list-style-type: none"> <li>■ The scanner is continuously seeing a bar code. Remove all bar code labels from the scan volume of the scanner and try again.</li> <li>■ The scanner cannot send the data to the host system. There is no proper handshaking between the scanner and the host. Scanner buffer is full. Make sure that all cables are connected and your host system is ready to receive data.</li> </ul>
<p>A bar code is read by the scanner but not accepted by the host system.</p>	<ul style="list-style-type: none"> <li>■ The communication cable is not connected to the serial port of your host system. Refer to the manual of your host system to locate the serial port.</li> <li>■ The communication settings of the host and scanner do not match. Ensure that the setting value for both devices are the same. For proper adjustment values see the Configuration Guide.</li> <li>■ The communication cable does not suit your host system. Contact your dealer for the correct communication cable.</li> <li>■ The data format is not supported by the software running on the host system.</li> </ul>

Scantech-ID BV  
Amersfoortsestraat 124  
3769 AN Soesterberg  
The Netherlands

Phone: +31 (0)33 469 84 00  
Fax: +31 (0)33 465 06 15  
E-mail: [info@scantech-id.com](mailto:info@scantech-id.com)  
Internet: [www.scantech-id.com](http://www.scantech-id.com)

---